



Main

Range of product	Modicon STB distributed I/O solution
Product or component type	Standard analog input kit
Kit composition	STBART0200 module STBXTS1100, 6-terminal screw type connector STBXBA1000 base STBXTS2100, 6-terminal spring clamp connector
Analogue input type	Voltage +/- 80 mV Temperature probe -100...+260 °C Cu 10 2, 3 or 4 wires IEC Temperature probe -100...+450 °C Pt 100 2, 3 or 4 wires US/JIS Temperature probe -100...+450 °C Pt 1000 2, 3 or 4 wires US/JIS Temperature probe -200...+850 °C Pt 100 2, 3 or 4 wires IEC Temperature probe -200...+850 °C Pt 1000 2, 3 or 4 wires IEC Temperature probe -60...+180 °C Ni 100 2, 3 or 4 wires IEC Temperature probe -60...+180 °C Ni 1000 2, 3 or 4 wires IEC Thermocouple +130...+1820 °C thermocouple B Thermocouple -200...+760 °C thermocouple J Thermocouple -270...+1000 °C thermocouple E Thermocouple -270...+1370 °C thermocouple K Thermocouple -270...+400 °C thermocouple T Thermocouple -50...+1665 °C thermocouple R Thermocouple -50...+1665 °C thermocouple S
Analogue input number	2
Analogue input resolution	15 bits + sign
Type of filter	Single low pass input filter 25 Hz

Complementary

Absolute maximum input	+/- 7.5 V DC
Cold swapping	Yes
Hot swapping fallback	Yes for standard NIMs
Fallback status	State 0 basic NIMs User configurable standard NIMs
Data format	EN 61131-2 IEC 61131-2
Input impedance	10 MOhm +/- 80 mV

Maximum supply current for sensors	100 mA per input channels
Protection type	Short-circuit protection
Absolute accuracy error	+/- 0.1 % of full scale 25 °C internal +/- 0.15 % of full scale 25 °C external
Insulation between channels and logic bus	1500 V for 1 minute
Addressing requirement	1 word for cold-junction compensation 2 input words
Product compatibility	Mounting base STBXBA1000 Power distribution module STBPDT3100/3105
[Us] rated supply voltage	24 V DC
Supply	Power distribution module
Current consumption	30 mA at 5 V DC for logic bus
Measurement resolution	0.01 mV voltage 0.1 °C or 0.1 °F temperature probe 0.1 °C or 0.1 °F thermocouple
Conversion time	150 ms voltage 60 Hz 170 ms voltage 50 Hz 180 ms temperature probe 60 Hz 2 or 4 wires 200 ms temperature probe 50 Hz 2 or 4 wires 210 ms thermocouple with internal cold-junction compensation 60 Hz 230 ms thermocouple with internal cold-junction compensation 50 Hz 300 ms temperature probe 60 Hz 3 wires 340 ms temperature probe 50 Hz 3 wires 360 ms thermocouple with external cold-junction compensation 60 Hz 400 ms thermocouple with external cold-junction compensation 50 Hz
Maximum wiring resistance	20 Ohm Cu 10 IEC/US/JIS 2 or 3 wires 20 Ohm Ni 100 IEC/US/JIS 2 or 3 wires 20 Ohm Pt 100 IEC/US/JIS 2 or 3 wires 200 Ohm Ni 1000 IEC/US/JIS 2 or 3 wires 200 Ohm Pt 1000 IEC/US/JIS 2 or 3 wires 50 Ohm Cu 10 IEC/US/JIS 4 wires 50 Ohm Ni 100 IEC/US/JIS 4 wires 50 Ohm Pt 100 IEC/US/JIS 4 wires 500 Ohm Ni 1000 IEC/US/JIS 4 wires 500 Ohm Pt 1000 IEC/US/JIS 4 wires
Measurement accuracy	+/- 1 °C Ni 100 25 °C external +/- 1 °C Ni 100 25 °C internal +/- 1 °C Ni 1000 25 °C external +/- 1 °C Ni 1000 25 °C internal +/- 1 °C Pt 100 25 °C internal +/- 1 °C Pt 1000 25 °C internal +/- 1.75 °C thermocouple B with external cold-junction compensation 25 °C +/- 1.75 °C thermocouple E with external cold-junction compensation 25 °C +/- 1.75 °C thermocouple J with external cold-junction compensation 25 °C +/- 1.75 °C thermocouple K with external cold-junction compensation 25 °C +/- 1.75 °C thermocouple R with external cold-junction compensation 25 °C +/- 1.75 °C thermocouple S with external cold-junction compensation 25 °C +/- 1.75 °C thermocouple T with external cold-junction compensation 25 °C +/- 2 °C Pt 100 25 °C external +/- 2 °C Pt 1000 25 °C external +/- 2.85 °C thermocouple B with external cold-junction compensation 60 °C +/- 2.85 °C thermocouple E with external cold-junction compensation 60 °C +/- 2.85 °C thermocouple J with external cold-junction compensation 60 °C +/- 2.85 °C thermocouple K with external cold-junction compensation 60 °C +/- 2.85 °C thermocouple R with external cold-junction compensation 60 °C +/- 2.85 °C thermocouple S with external cold-junction compensation 60 °C +/- 2.85 °C thermocouple T with external cold-junction compensation 60 °C +/- 3.6 °C thermocouple R with internal cold-junction compensation 25 °C +/- 4 °C Cu 10 25 °C external +/- 4 °C Cu 10 25 °C internal +/- 4 °C thermocouple K with internal cold-junction compensation 25 °C +/- 4.1 °C thermocouple S with internal cold-junction compensation 25 °C +/- 4.2 °C thermocouple R with internal cold-junction compensation 60 °C +/- 4.4 °C thermocouple T with internal cold-junction compensation 25 °C +/- 4.6 °C thermocouple B with internal cold-junction compensation 25 °C +/- 4.6 °C thermocouple E with internal cold-junction compensation 25 °C +/- 5 °C thermocouple S with internal cold-junction compensation 60 °C +/- 5.1 °C thermocouple J with internal cold-junction compensation 25 °C +/- 5.5 °C thermocouple K with internal cold-junction compensation 60 °C +/- 6.4 °C thermocouple T with internal cold-junction compensation 60 °C

+/- 6.8 °C thermocouple B with internal cold-junction compensation 60 °C
 +/- 6.8 °C thermocouple E with internal cold-junction compensation 60 °C
 +/- 7 °C thermocouple J with internal cold-junction compensation 60 °C

Marking	CE
Overvoltage category	II
Status LED	1 LED (green)module status (RDY): 1 LED (red)module error (ERR):

Environment

Product certifications	UL FM Class 1 Division 2 CSA ATEX Cat 3G C-Tick
Pollution degree	2 conforming to IEC 60664-1
Operating altitude	<= 2000 m
IP degree of protection	IP20 conforming to EN 61131-2 class 1
Ambient air temperature for operation	0...70 °C
Ambient air temperature for operation	32...140 °F without
Ambient air temperature for storage	-40...85 °C without
Ambient air temperature for storage	-40...185 °F without
Relative humidity	95 % at 60 °C without condensation
Vibration resistance	+/-0.35 mm at 10...58 Hz 3 gn at 58...150 Hz on 35 x 7.5 mm symmetrical DIN rail 5 gn at 58...150 Hz on 35 x 15 mm symmetrical DIN rail
Shock resistance	30 gn for 11 ms conforming to IEC 88 reference 2-27

Offer Sustainability

Sustainable offer status	Green Premium product
REACH Regulation	REACH Declaration
EU RoHS Directive	Pro-active compliance (Product out of EU RoHS legal scope) EU RoHS Declaration
Mercury free	Yes
RoHS exemption information	Yes
China RoHS Regulation	China RoHS declaration
Environmental Disclosure	Product Environmental Profile
Circularity Profile	End of Life Information
WEEE	The product must be disposed on European Union markets following specific waste collection and never end up in rubbish bins

Contractual warranty

Warranty	18 months
----------	-----------

Dimensions

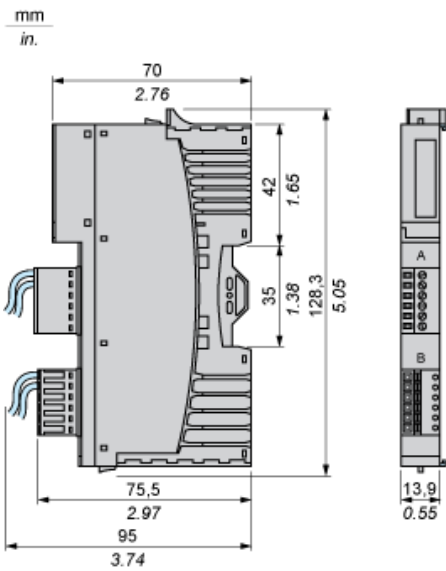

Wiring Diagrams

Examples

2 and 3-wire temperature probes

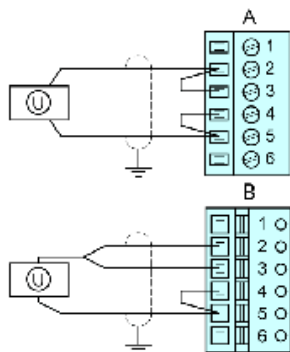

4-wire temperature probes

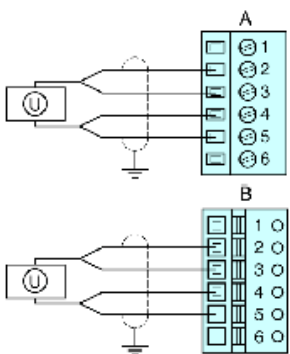

2-wire temperature probes in highly disturbed environments

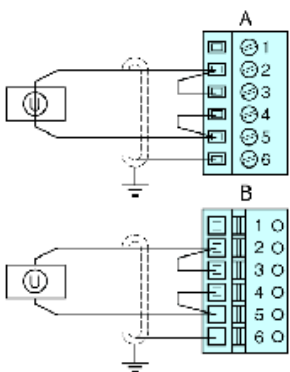

2-wire thermocouple and voltage sensor (mV)

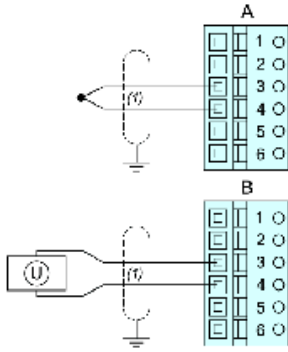

2-wire thermocouple and voltage sensor (mV) with cold-junction compensation

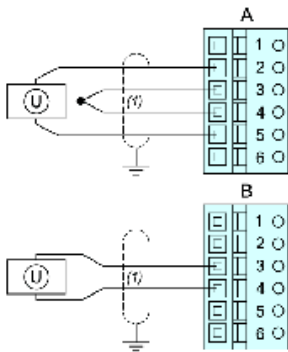

Pin	Top Connections	Bottom Connections
1	no connection	no connection
2	Always used for RTD +	Always used for RTD +
	RTD + connection for external cold-junction compensation on a TC sensor	
	no connection for TC or mV	
3	TC + or mV + connection	TC + or mV + connection
	Either used or jumpered for a two-, three-, or four-wire RTD	Either used or jumpered for a two-, three-, or four-wire RTD
4	TC - or mV - connection	TC - or mV - connection
	Either used or jumpered for a two-, three-, or four-wire RTD	Either used or jumpered for a two-, three-, or four-wire RTD
5	Always used for RTD -	Always used for RTD -
	RTD - connection for external cold-junction compensation on a TC sensor	
	no connection for TC or mV	
6	inner double-shield cable	cable shield