



**Jean Noël Fiorina**

Joined Merlin Gerin in 1968 as a laboratory technician in the ACS (Alimentations et Convertisseurs Statiques) department where he participated in the performance setting up procedures for static converters. In 1977 he obtained his ENSERG Engineering degree following a 3 years evening course and rejoined the ACS department. Starting as development engineer he was soon afterwards entrusted with projects. He became later responsible for design projects in EPS department (Electronic Power System).

He is in some ways the originator of medium and high power inverters. At present he is with the UPS Division where, as responsible for Innovations he works on the preparation of new UPS designs of tomorrow.

**n° 159**

**inverters and harmonics**

**(case studies of non-linear loads)**

## **glossary**

---

UPS	Uninterrupted Static Power Supply - Static UPS
IEC	International Electrotechnical Commission
CIGREE	Conférence Internationale des Grands Réseaux Electriques et Electroniques (International conference on high voltage electric systems)
PWM	Pulse Width Modulation
D	global distortion rate
H <sub>n</sub>	individual ratio of harmonics of order n
$\varphi_n$	phase angle shift of harmonic component at t = 0
I <sub>n</sub>	effective current of harmonic component of order n
U <sub>ref</sub>	reference voltage
v	distortion factor
V <sub>n</sub>	effective voltage of harmonic component of order n
Z <sub>sn</sub>	output impedance for harmonic of order n

---

# inverters and harmonics (case studies of non-linear loads)

## summary

<b>1. Introduction</b>		p. 4
<b>2. Characteristics of non-sinusoidal alternating quantities</b>	Harmonic analysis of a periodic function	p. 4
	Effective value of a non-sinusoidal alternating quantity	p. 4
	Distortion rate	p. 4
	Power factors and $\cos \varphi_1$	p. 5
	Distortion factor $v$	p. 5
	Crest factor	p. 5
	Relation between current distortion and voltage distortion	p. 5
<b>3. Impedances of some conventional sources</b>	Impedance of a transformer	p. 6
	Impedance of an alternator	p. 7
	Output impedance of an inverter	p. 7
	Impedance of line	p. 11
<b>4. Micro and mini-computer loads</b>	Description	p. 12
	Influence of source impedance	p. 12
	Calculation of source power for supplying RCD type loads	p. 13
<b>5. Conclusion</b>		p. 16
<b>Appendix 1: influence of line impedances on voltage distortions</b>		p. 16
<b>Appendix 2: input filters in computer/micro-processor equipment</b>		p. 18
<b>Appendix 3: bibliography</b>		p. 19

# 1. introduction

Static UPS are virtually perfect electric generators.

They are highly **reliable** and, by nature, ensure (within the performance limits of the battery) the uninterrupted **availability** of electric power.

As regards electrical characteristics, the inverter (which constitutes the UPS generator) possesses from the point of

view of **frequency stability** as well as **voltage stability**, performances superior to those of the mains.

The only doubtful characteristic is, in the opinion of many engineers, its ability to deliver a sinusoidal voltage regardless of the shape of the current drawn by the load.

The aim of this «Cahier Technique» is to clarify this point and to demonstrate

that modern inverters are excellent generators of sinusoidal voltage even when they supply non-linear loads.

This is considered quite normal as UPS are designed and very often utilised to supply computer/microprocessor systems which draw non-sinusoidal currents.

# 2. characteristics of non-sinusoidal alternating quantities

## harmonic analysis of a periodic function

As alternating non-sinusoidal currents and voltages are the main topic of this study, it will be worth while to review the electric quantities in the presence of harmonics.

Fourier theorem states that any non-sinusoidal periodic function can be represented by a series of terms consisting:

- of a sinusoidal term at fundamental frequency,
- of sinusoidal terms whose frequencies are whole multiples of the fundamental (harmonics),
- and eventually of a continuous component (DC component).

The formula denoting the harmonic analysis of a periodic function is as follows:

$$y(t) = Y_0 + \sum_{n=1}^{n=\infty} Y_n \sqrt{2} \sin(n\omega t - \varphi_n)$$

where:

Y<sub>0</sub>: value of continuous component generally equal to zero and considered as such hereafter,

Y<sub>n</sub>: effective value of harmonic of order n,

ω: pulsation of fundamental frequency,

φ<sub>n</sub>: phase shift angle of harmonic component at t = 0.

## effective value of a non-sinusoidal alternating quantity

Applying the general formula

$$Y_{rms} = \sqrt{\frac{1}{T} \int_0^T y^2(t) dt}$$

gives with harmonic representation:

$$Y_{rms} = \sqrt{\sum_{n=1}^{n=\infty} Y_n^2}$$

## distortion rates

### Harmonic rates

(as defined in IEC dictionary)

This parameter, also called harmonic distortion or distortion factor represents the ratio of the effective value of harmonics (n ≥ 2) to that of the alternating quantity:

$$THD \% = DF \% = 100 \frac{\sqrt{\sum_{n=2}^{n=\infty} Y_n^2}}{\sqrt{\sum_{n=1}^{n=\infty} Y_n^2}}$$

### Global rate of distortion (as defined by CIGREE)

This parameter represents the ratio of the effective value of harmonics to that of the fundamental alone:

$$D \% = 100 \frac{\sqrt{\sum_{n=2}^{n=\infty} Y_n^2}}{Y_1}$$

**Note:** when the distortion rate is low, as is most frequently the case for the voltage, the two definitions lead in practice to the same result.

For example, if:

$$\sqrt{\sum_{n=2}^{n=\infty} Y_n^2} = 10 \% \text{ de } Y_1$$

The IEC expression gives:

$$THD = DF = 100 \frac{\sqrt{(0.1)^2}}{\sqrt{1 + (0.1)^2}} = 9.95 \%$$

Whereas the CIGREE expression gives:

$$D \% = 100 \frac{0.1}{1} = 10 \%$$

Hereafter we shall retain for the distortion rate, the expression «D» which corresponds to a more analytical view of the influence of harmonics on a non-deformed wave.

### Individual harmonic rate

This parameter represents the ratio of the effective value of a harmonic of order  $n$  to that of the alternating quantity (according to IEC dictionary) or to that of the fundamental alone (according to CIGREE),

■ according to definition in IEC dictionary:

$$H_n \% = 100 \frac{Y_n}{\sqrt{\sum_{n=1}^{\infty} Y_n^2}}$$

■ and according to CIGREE definition:

$$H_n \% = 100 \frac{Y_n}{Y_1}$$

This latter definition will be retained in subsequent reasoning.

### power factors and $\cos \varphi_1$

According to IEC, the power factor is the ratio of the effective power  $P$  to the apparent power  $S$ :

$$\lambda = \frac{P}{S}$$

This power factor should not be confused with the phase shift angle factor ( $\cos \varphi_1$ ) which represents the cosine of angle formed by the phase elements of fundamental components of voltage and current:

$$\lambda_1 = \cos \varphi_1 = \frac{P_1}{S_1}$$

where:

$P_1$  = effective power of fundamental component

$S_1$  = apparent power of fundamental component.

### distortion factor $v$

According to standard specification IEC 146-1-1, this factor enables to define the relation between power factor  $\lambda$  and  $\cos \varphi_1$ :

$$v = \frac{\lambda}{\cos \varphi_1}$$

Where voltages and currents are perfectly sinusoidal the distortion factor equals 1 and  $\cos \varphi_1$  is equal to the power factor.

### crest factor

As defined by IEC, it is the ratio of crest value to the effective value of a periodic quantity.

### relation between current distortion and voltage distortion

For a given voltage source, it is always possible to define an output impedance, even if the latter is frequency dependent. To the extent where this impedance is independent of the current value (linear case) it is possible to calculate for each current harmonic a corresponding voltage harmonic and thus to deduce the individual harmonic rate (percentage). The effective value of voltage harmonic of order  $n$  equals:

$$U_n = Z_{sn} \cdot I_n$$

where

$Z_{sn}$ : output impedance for harmonic  $n$  and

$I_n$ : effective current of harmonic  $n$ .

The individual rate of harmonics of order  $n$  for this voltage is equivalent to:

$$H_n = \frac{U_n}{U_1}$$

where

$U_1$  = effective value of fundamental voltage.

The global distortion rate of voltage is thus obtained by means of expression:

$$D \% = 100 \frac{\sqrt{\sum_{n=2}^{\infty} U_n^2}}{U_1}$$

and also:

$$D \% = 100 \sqrt{\sum_{n=2}^{\infty} H_n^2}$$

The input impedance for various harmonic frequencies plays therefore an important role in bringing about the onset of voltage distortion. The higher this input impedance, the greater will be the voltage distortion rate for a given non-sinusoidal current.

### 3. impedances of some conventional sources

Very often the impedance  $Z_s$  (at 50 Hz) of a generator is given as percentage of nominal impedance of load  $Z_c$ :

$$Z_s \% = 100 \frac{Z_s}{Z_c}$$

For the nominal current, the voltage drop across this impedance represents, therefore, as percentage in relation to the nominal voltage, the value of this source impedance:

$$\frac{Z_s \cdot I_n}{U_n} \% = 100 \frac{Z_s \cdot I_n}{U_n}$$

where  $Z_c \cdot I_n = U_n$

$$\frac{Z_s \cdot I_n}{U_n} \% = 100 \frac{Z_s \cdot I_n}{Z_c \cdot I_n} = 100 \frac{Z_s}{Z_c}$$

#### impedance of a transformer

Figure 1 represents an equivalent circuit diagram of a single phase transformer seen from secondary winding.

The transformer impedance consists of an inductance  $L$  in series with a resistance  $R$ . An equivalent value of the relative impedance is given by the transformer short-circuit voltage  $U_{cc}$ .

Indeed, by definition, the short-circuit voltage is the voltage that must be applied across a winding in order to induce a nominal current in the other winding also under short-circuit,

$$U_{cc} \% = 100 \frac{U_{cc}}{U_n}$$

$$U_{cc} \% = 100 \frac{Z_s \cdot I_n}{U_n} = 100 \frac{Z_s}{Z_c} = Z_s \%$$

This short-circuit voltage is made up of two terms:  $U_{ccR}$  et  $U_{ccx}$  (see fig. 2).

■ in distribution transformers or general purpose transformers with ratings superior to 1 kVA, the value of  $U_{ccx}$  ranges from 4 - 6 %, whereas the value

of  $U_{ccR}$  is of the order of 1 % to several % (this latter value becoming correspondingly smaller as the power rating of transformer increases).

In practice, as regards harmonics, since only the inductance impedance is frequency dependent, it is the inductance alone which determines the behaviour/performance of the transformer.

■ in three phase transformers, it is necessary to take into account the different possible connection types of primary and secondary windings, as these exert an influence on the source impedance for some harmonics (in particular, third harmonic and multiples of 3).

In fact, in the case of a transformer which supplies to each of its secondary windings distorted and balanced currents comprising harmonics of order 3 and multiples of 3, say  $3k$ , and considering that these currents are balanced, it is thus possible to write for each of these phases:

$$I_{1\ 3k} = I \sin 3k \ \omega t$$

$$I_{2\ 3k} = I \sin 3k \left( \omega t - \frac{2\pi}{3} \right)$$

$$I_{3\ 3k} = I \sin 3k \left( \omega t - \frac{4\pi}{3} \right)$$

or

$$I_{1\ 3k} = I \sin 3k \ \omega t$$

$$I_{2\ 3k} = I \sin (3k \ \omega t - k \ 2\pi)$$

$$I_{3\ 3k} = I \sin (3k \ \omega t - k \ 4\pi)$$

These equations show that the three currents are in phase. It is this phenomenon which leads one to observe in the neutral conductor of some wiring installations (neon tubes for example) the presence of much higher currents than originally anticipated.

The behaviour of a transformer towards these harmonics is therefore dependent on the homopolar impedance  $Z_h$  of the transformer (refer to «Cahier Technique» n° 18 «Analyse des réseaux triphasés en régime perturbé à l'aide des composantes symétriques»).

Two types of secondary windings are suitable for not amplifying or reducing harmonic distortions:

■ star connected secondary with «distributed» neutral

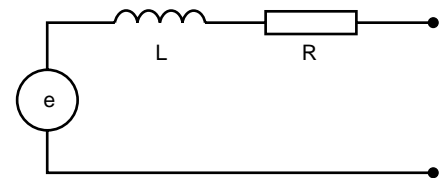

fig. 1: equivalent circuit diagram of a single phase transformer seen from secondary winding.

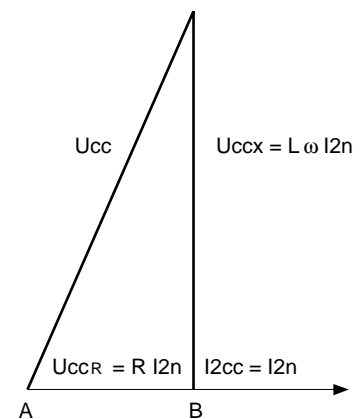

fig. 2: Kapp triangle of a transformer (values referred to secondary).

When primary windings are delta or star connected with the neutral point connected to the source neutral (see fig. 3), the harmonic impedances of order 3 and multiples are neither encouraged nor discouraged ( $Z_h = Z_d$ ).

The transformer behaves as three single phase transformers.

■ **ZIGZAG connected secondary**  
 These connections ensure minimum distortion in secondary - in fact, in this case, the harmonic currents of order 3 k do not circulate in the transformer primary, and the impedance  $Z_s$  is no longer dependent on secondary windings. The inductance is thus very low:  $U_{ccx} \approx 1\%$ , and the resistance is reduced roughly by half when compared with the resistance of delta star connected transformer of same rating.

Figure 4 and the following calculation explain why currents of pulsating frequency  $3\omega$  are not found in the transformer primary (homopolar current equal to zero).

For a turn ratio  $\frac{N_2}{N_1}$ ,

the current circulating for instance in the primary winding 1 equals:

$$\frac{N_2}{N_1} (i_1 - i_3)$$

with

$$i_1 = I_{13k} = I \sin 3k\omega t$$

$$i_3 = I_{33k} = I \sin 3k\left(\omega t - \frac{4\pi}{3}\right) = I \sin (3k\omega t - 4\pi)$$

this gives

$$\frac{N_2}{N_1} (i_1 - i_3) = 0$$

The ZIGZAG connected secondary winding acts therefore as an attenuator to harmonics of order 3 k. This type of transformer is often used as an output transformer for classic inverters of high rating.

As a general rule, the other types of connection are to be avoided, in particular those that do not allow the neutral to be «distributed» in the secondary; in fact for these  $Z_h = \infty$ .

### impedance of an alternator

An alternator can also be represented by a voltage source in series with an inductance and a resistance.

However, this inductance assumes very different values according to the speed of current variations to which it is related.

During such current variation, the equivalent reactance passes progressively from a value called sub-transient to its synchronous value via a transient value. These different values reflect the variation of the alternator magnetic flux.

As regards current harmonics, only the sub-transient reactance is to be considered in any phenomenon lasting less than 10 ms.

This reactance, referred to as «longitudinal sub-transient reactance» is denoted as  $X''_d$ .

For an alternator of current production, this reactance amounts to 15 - 20 %. In traditional machines but of design optimised in this respect, a value of 12 % can be achieved.

Finally, in special machines, some constructors claim values decreasing to 6 %.

In conclusion, it is worth recalling that, except in very particular cases, the alternator output impedance is considerably greater than that of a transformer; consequently, the same applies to the voltage distortion rate in the presence of distorted currents.

### output impedance of an inverter

The impedance of an inverter is essentially dependent on the output impedance of its filter and on the type of regulation adopted.

### Principle of an inverter

An inverter comprises first of all a converter referred to as «mutator» i.e. switching device which converts the DC voltage supplied by a rectifier or a DC battery into AC voltage.

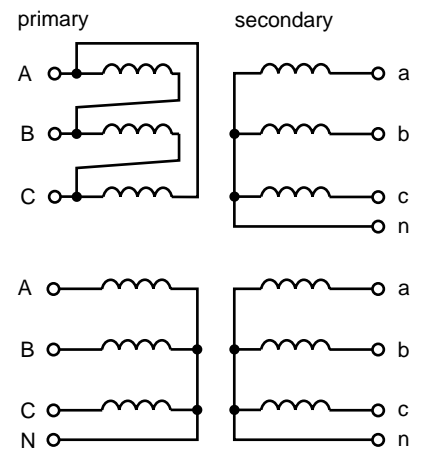

fig. 3: winding connections of three-phase transformers which have a homopolar impedance  $Z_h$  equal to a direct impedance  $Z_d$ .

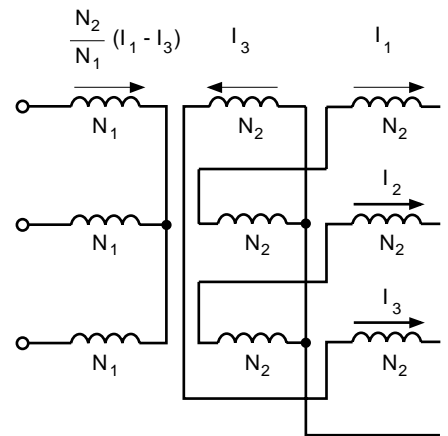

fig. 4: transformer with ZIGZAG connected secondary and attenuation of harmonics of order 3 k.

In a single phase unit, there are two ways of achieving this conversion:

- half-bridge converter (see fig. 5a),
- full-bridge converter (see fig. 5b).

The square wave voltage appearing between A and B is then filtered so as to obtain in the output of the unit a sinusoidal voltage wave with a low distortion rate.

In practice, the switching device (mutator) produces several positive and negative pulses (see fig. 6) which makes it possible to reduce the size of the filter and to have a faster acting voltage regulator.

By modulating the relative time intervals corresponding to conduction and non-conduction periods, it is possible to «spread» the voltage during the period in such a way as to make the conduction time of the switching device practically proportional to the instantaneous value of the fundamental.

This principle is called PWM (Pulse Width Modulation) - (MLI in french).

The filter inserted behind the switching device (mutator) is generally of the L and C type (see fig. 7).

The inverter is therefore a voltage source with the filter impedance in series.

Voltage  $V$  is the voltage measured at no load, and the impedance consisting of L and C elements in parallel is the impedance measured when terminals A and B are short-circuited (obtained by applying Thevenin theorem; see fig. 8).

**Classic inverters**

When the commutation frequency is low, regulation can:

- cope with variations of current drawn by user equipment,
- compensate for voltage variation of DC battery (or rectifier),
- have, however, difficulties in dealing permanently with variations of current due to harmonics generated during half cycle.

In these inverters, the output impedance is equal to the impedance of their filter. They can, therefore, be described as classic inverters since

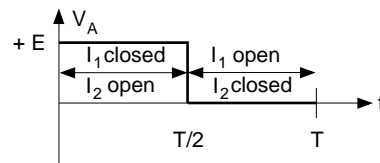
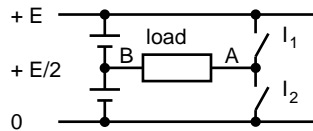

fig. 5a: principle of switching unit (mutator) half-bridge converter.

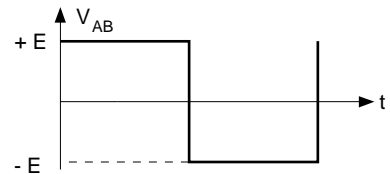
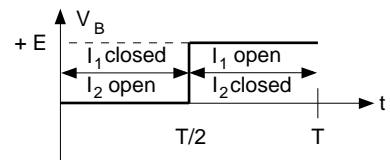
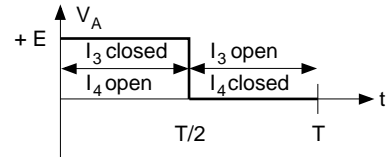
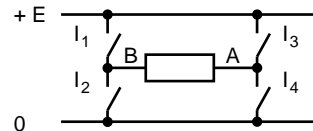

fig. 5b: principle of mutator full-bridge converter.

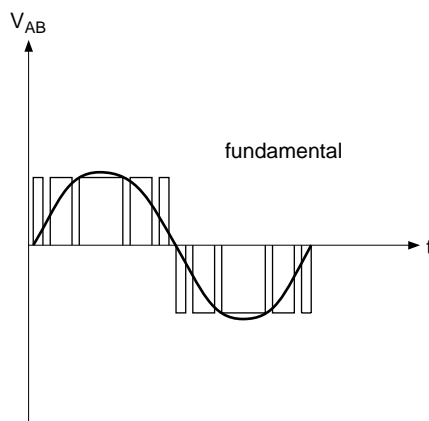

fig. 6: output voltage of switching unit (mutator) with 5 pulses per half period.

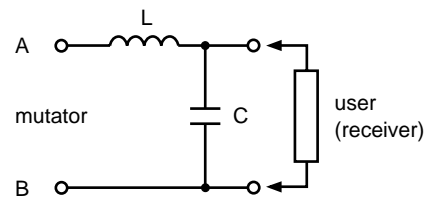

fig. 7: output filter of an inverter.

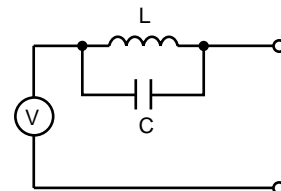

fig. 8: equivalent circuit diagram of an inverter seen from its output.



operationally they function in the same way as the early design units (due to the limited capacity of semi-conductors to operate at high frequencies).

The output impedance of these inverters is therefore frequency dependent and can be represented by the diagram used in figure 9.

■ thus at low frequencies the impedance of the filter is nearly equal to  $L\omega$ .

■ at high frequencies the filter impedance differs little from  $\frac{1}{C\omega}$ .

■ at resonant frequency

$$F_0 = \frac{1}{2\pi\sqrt{LC}}$$

the impedance of the filter assumes a high value that can attain, in terms of magnitude, the value of the nominal load impedance of the equipment ( $Z_s = 100\% Z_c$ ).

In practice, frequency  $F_0$  is therefore chosen so as not to correspond to the possible frequency of current harmonic, i.e. 210 Hz (harmonic currents of order 4 are non-existent or are of very small amplitude). This being the case, various ingenious ways have been devised by constructors in an effort to reduce the output impedance.

For example:

- additional filters,
- special connection circuits for the transformer inserted behind the three-phase switching device (mutator).

At first sight, classic inverters have a behaviour towards harmonic currents comparable to that of well designed alternators and therefore less satisfactory than that of transformers.

### Inverters with PWM and appropriate regulation

When the switching frequency of the switching unit (mutator) is high (at least several kHz) and the regulation system allows rapid intervention through the modification to pulse widths during the same period, it is naturally possible to maintain the inverter output voltage within its distortion limits even when dealing with highly distorted currents.

The block diagram of such inverter, shown in figure 10 is as follows:

The output voltage  $V_s$  is constantly compared with a reference voltage  $U_{ref}$  which is sinusoidal and has a very low distortion rate ( $< 1\%$ ).

The voltage difference  $\epsilon$  is then processed by a correction circuit of transfer function  $C(p)$  whose aim it is to ensure the performances and the stability of control circuit systems. The resulting voltage issued from this correction circuit is then amplified by the switching unit (mutator) itself and its ancillary control circuit with an amplification gain  $A$ .

The voltage  $V_m$  supplied by the switching unit is shaped by the filter consisting of  $L$  and  $C$  elements before becoming the output voltage  $V_s$ .

In practice, one should take into account:

- the impedance of the transformer, if present in the circuit, in order to obtain the total value of inductance (often the inductance is integrated within the transformer. That is why it does not appear in circuit diagrams),
- the output impedance of the switching unit which according to designs, is not necessarily negligible.

In general, it is then useful to show the whole output circuit part (switching unit + filter) in the form of a series impedance  $Z_1$  together with a parallel impedance  $Z_2$  (see fig. 11).

By applying Thevenin theorem, it is possible to transform the circuit diagram into that shown in figure n° 12.

$V'_m$  = voltage measured at no load thus:

$$V'_m = V_m \cdot \frac{Z_2}{Z_1 + Z_2}$$

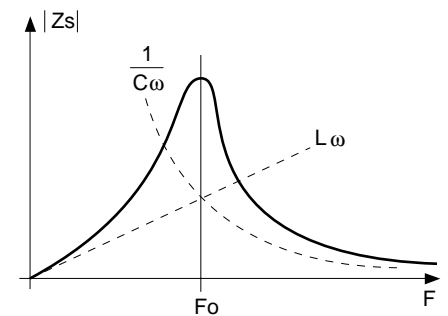

fig. 9: variation of output impedance in a classic inverter with frequency.

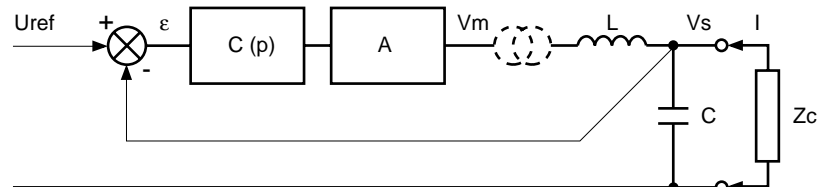

fig. 10: block diagram of a PWM inverter.

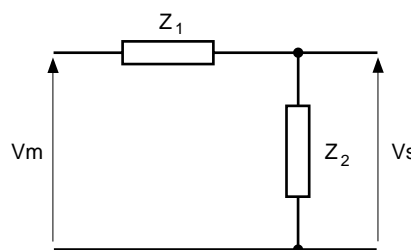

fig. 11: equivalent circuit diagram of a switching unit seen from output.

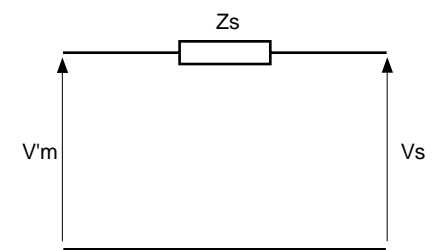

fig. 12: transformed equivalent circuit diagram of switching unit seen from output.

$Z_s$  = measured in output by short-circuiting  $V_m$ , thus:

$$Z_s = \frac{Z_1 \cdot Z_2}{Z_1 + Z_2}$$

Ratio  $\frac{Z_2}{Z_1 + Z_2}$  is the transfer function of the filter, say  $H(p)$ :

$$\text{thus } H(p) = \frac{Z_2}{Z_1 + Z_2}$$

To simplify still further, it is convenient to replace the product  $C(p) \times A$  by  $\mu(p)$  which represents the transfer function of action chain.

The block diagram becomes that shown in figure 13, where  $Z_s$  = output impedance in the absence of regulation as is the case in classic inverters.

When a current is drawn by the load, a voltage drop appears at the terminals of the output impedance  $Z_s$ , such that:

$$V_1 - V_s = Z_s I$$

Developing still further:

$$V_1 = \varepsilon \cdot \mu(p) \cdot H(p)$$

$$\varepsilon = V_{ref} - V_s$$

$$V_1 = (V_{ref} - V_s) \cdot \mu(p) \cdot H(p)$$

$$V_1 = V_s + Z_s I$$

$$V_s + Z_s I = (V_{ref} - V_s) \cdot \mu(p) \cdot H(p)$$

thus:

$$V_s [1 + \mu(p) \cdot H(p)] =$$

$$V_{ref} \mu(p) \cdot H(p) - Z_s I$$

thus:

$$V_s = V_{ref} \cdot \frac{\mu(p) \cdot H(p)}{1 + \mu(p) \cdot H(p)} - \frac{Z_s I}{1 + \mu(p) \cdot H(p)}$$

The first term represents the result obtained for a conventional control system with no disturbance present.

Here, the disturbance is introduced by means of current  $I$  circulating in the internal impedance  $Z_s$ .

In the absence of regulation, the term denoting the disturbance would have assumed a value of  $Z_s I$ .

With regulation, this disturbance is limited to:

$$\frac{Z_s I}{1 + \mu(p) \cdot H(p)}$$

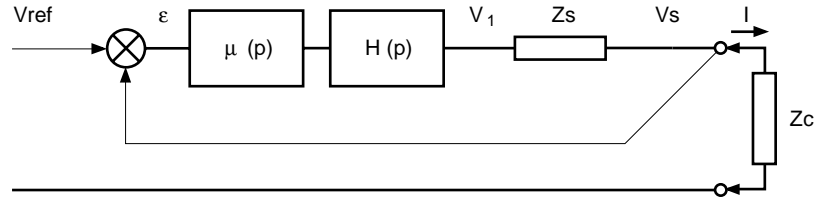

fig. 13: transformed block diagram of a PWM inverter.

Everything happens as if the output impedance of the inverter were divided by  $1 + \mu(p) \cdot H(p)$ .

To throw further light on this impedance, it is convenient to carry out additional calculations.

In the band-pass of regulation, the product  $\mu(p) \cdot H(p)$  being  $\geq 1$ , calculations are as follows:

$$1 + \mu(p) \cdot H(p) \approx \mu(p) \cdot H(p)$$

$$Z'_s \approx \frac{Z_s}{\mu(p) \cdot H(p)}$$

since

$$Z_s = \frac{Z_1 \cdot Z_2}{Z_1 + Z_2}$$

and

$$H(p) = \frac{Z_2}{Z_1 + Z_2}$$

thus

$$Z'_s \approx \frac{Z_1 \cdot Z_2}{Z_1 + Z_2} \cdot \frac{1}{\mu(p)} \cdot \frac{Z_1 + Z_2}{Z_2}$$

thus

$$Z'_s \approx \frac{Z_1}{\mu(p)}$$

This means that in the band-pass of regulation, the output impedance of inverter is equal to the series impedance of the filter for the whole output circuit divided by the amplification gain of the action chain.

Beyond the band-pass of regulation, the output impedance becomes again the impedance of filter which by then becomes the impedance of a capacitor offering a low impedance at high frequencies. Hence the shape of the curve of output impedance in function of frequency (see fig. 14).

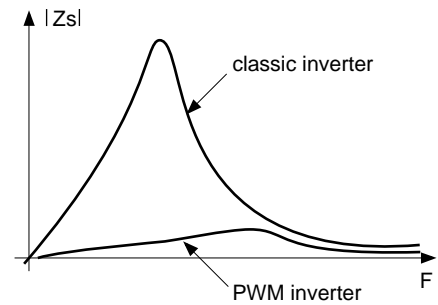

fig. 14: comparison of output impedances between classic inverter and PWM inverter in function of frequency.

With PWM inverters, the output impedance remains very low up to high frequencies and the output voltage distortion due to circulating currents, even highly distorted currents, is negligible.

#### Limitation of current

The semi-conductors utilized in switching units can deliver a maximum current, above which their performance can no longer be guaranteed. It is therefore advisable to limit the current to this maximum value in order to ensure reliability of performance.

As soon as the current drawn by the load exceeds the maximum value set for the inverter, the latter becomes a generator of constant current until the current value required by the load drops below the fixed threshold limit.

Under these conditions, the output voltage does not follow the shape of the reference voltage and remains distorted as long as the load current exceeds the threshold limit.

This voltage distortion is all the more significant, the longer the duration stage above the threshold limit.

Such cases are met essentially when single-phase loads consisting of a capacitor in front of a rectifier giving a high crest factor. The latter is usually of the order of 3 (crest value  $\approx 3$  times the effective value of current) whereas for a pure sine wave it is only  $\sqrt{2}$ .

The performance of the PWM inverter for this type of load is examined in chapter 4.

## impedance of line

There is always a length of cable of greater or lesser importance between the voltage source and each user installation.

### Value of line impedance

The line impedance consists essentially of an inductance  $L$  in series with a resistance  $R$  (see fig. 15). The value of the inductance is hardly dependent on the section of conductors and is usually assumed to be  $0.1 \Omega/\text{km}$  (at 50 Hz) which is roughly equivalent to  $0.3 \mu\text{H}/\text{m}$ .

The value of the resistance is dependent on the section of the cable and is taken as  $r = 20 \Omega/\text{km}$  for  $1 \text{ mm}^2$  section.

For example, a cable of  $16 \text{ mm}^2$  section exhibits a resistance of  $1.25 \Omega/\text{km}$  and a reactance of only  $0.1 \Omega/\text{km}$ .

As a first approximation, it will be possible to represent a cable by its resistance only in the case of small and medium size power rating installations where the use of small section conductors is quite common.

**Note:** for harmonic frequencies, it might be necessary to take into account the skin effect.

In this respect, one must remember that in a copper conductor, the equivalent conduction thickness, referred to as skin thickness, is given by the formula:

$$a \text{ (mm)} = \frac{66}{\sqrt{F \text{ (Hz)}}}$$

Thus, at 50 Hz the skin thickness is 9.3 mm, whereas at 1 kHz it is reduced to 2.1mm.

The skin effect must therefore be taken into account for large section conductors which generally carry harmonic currents of high order.

## Influence of line impedance on voltage distortion

Since the line impedance is additional to the source impedance, it has the effect of increasing the distortion rate of the voltage in installations drawing distorted currents.

Figure 16 shows an example where an user installation  $U_2$  draws a highly distorted current. When this occurs, the distortion rate measured at its input terminals is  $D_2$ ; however, because of the impedance divider consisting of  $Z_s$  and  $Z_{L_2}$ , a distortion rate  $D$  is measured at the output terminals of the source  $D$  being smaller than  $D_2$ .

Consequently, to minimise the influence of receiver installations which generate harmonic currents in other «receivers», it is recommended to supply the receiver installations through a special line. Readers interested in further details can refer to appendix 1.

## In conclusion

Figure 17 below shows the variation of output impedances of various sources of same power rating with frequency.

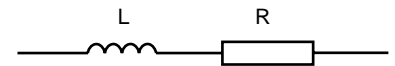

fig. 15: equivalent circuit diagram of line.

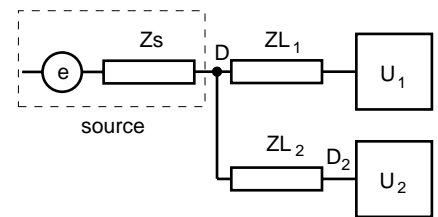

fig. 16: supply to polluter receiver ( $U_2$ ) by means of special line.

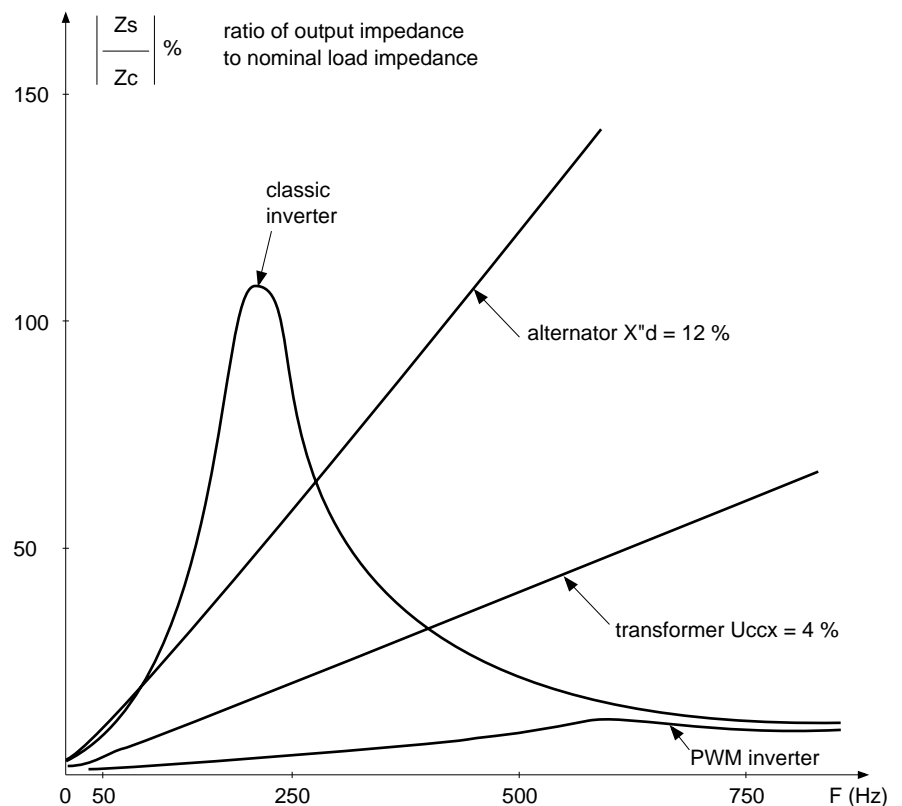

fig. 17: output impedance of different sources in function of frequency.

It is clearly apparent that the PWM inverter exhibits by far the lowest output impedance. To better clarify this point, figure 18 shows three sources, each with the same impedance at 150 Hz.

It is thus obvious that the impedance of a classic transformer as well as the impedance of the supply line, must both be taken into account when distorted currents are to be supplied to a load.

The PWM Inverter is by far the best generator on the market as regards its ability to minimise the voltage harmonic distortion. It is 5 to 6 times better than a transformer of the same rating.

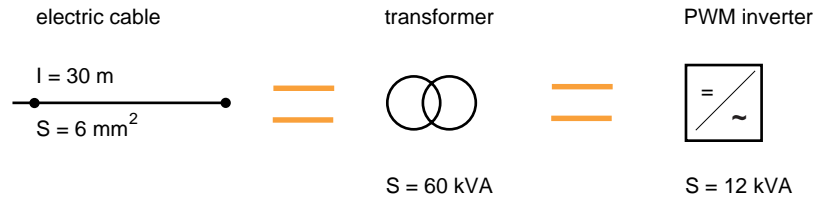

fig. 18: sources exhibiting same impedance at 150 Hz.

## 4. micro and mini-computer loads

### description

These single-phase loads, as many other types of electronic equipment, are supplied by means of switched-mode power supplies.

Thus, a load of RCD type (Resistances, Capacitors, Diodes) has been retained in Standard Specification NF C 42-810 to characterise inverters of rating below 3 kVA.

A load of RCD type consists of a Graetz full-bridge converter and preceded by a capacitor. The latter acts as an energy storage reservoir in order to supply current to the load between two successive peaks of the rectified voltage.

The supply source is represented by a voltage  $e$  and an output impedance  $Z_s$ .

In the examples cited in this chapter, the time constant of discharge of the capacitor through the resistance is fixed at 125 ms (see fig. 19).

Current  $i$  starts flowing when voltage  $e$  exceeds the DC voltage  $U$  and circulates for a relatively short time to recharge the capacitor to its nominal voltage.

Figure 20 shows the voltages and currents obtained with a relatively low source impedance consisting of an inductance and a resistance such that their short-circuit voltages referred to the load power are respectively  $U_{ccx} = 2\%$  and  $U_{CCR} = 2\%$ .

It must be pointed out the distortion rate of the voltage  $v$  in the rectifier input is already important as it reaches 7.5% even despite a low source impedance.

The current  $i$  starts flowing as soon as the voltage  $e$  becomes higher than  $U$  but its rate of rise is limited by the source inductance.

This inductance extends the time of current circulation when voltage  $e$  becomes again smaller than  $v$ . It is therefore essentially the value of the source inductance which determines the shape of current  $i$ .

It is apparent that the current is highly distorted compared with a perfect sine wave and, in addition, slightly out of phase with respect to the source voltage. In this example, the power factor is equal to 0.72.

### influence of source impedance

In the previous example it is shown that the load cannot be considered as a generator of harmonic current, but on the contrary, that the current is highly dependent on the source impedance.

Figure 21 shows the variation of current  $i$  and voltage  $v$  in the rectifier input when the source impedance changes from  $U_{ccx} = 0.25\%$  to  $U_{ccx} = 8\%$

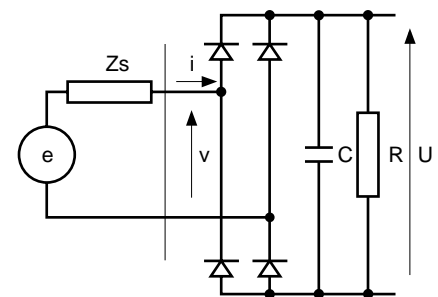

fig. 19: basic circuit diagram of micro and mini-computer type load.

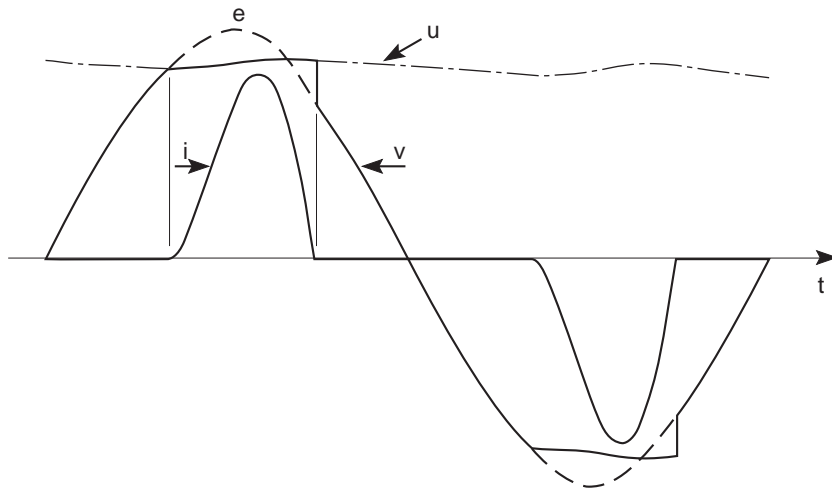

fig. 20: currents and voltages of a computer type load of 1 kW with source such that:  $U_{ccx} = 2\%$  and  $U_{CCR} = 2\%$ .

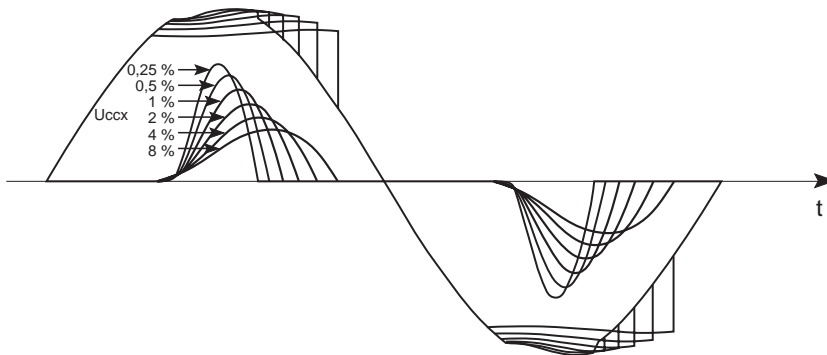

fig. 21: variation of current and voltage at the computer type load input when the short-circuit voltage  $U_{ccx}$  changes from 0.25 % to 8 % while the short-circuit voltage  $U_{CCR}$  remains constant and equal to 2 %.

whilst the resistive part has been arbitrarily fixed at  $U_{CCR} = 2\%$ .

Table in figure 22 brings to light, for these different impedances, the variation of the different characteristic parameters relating to current and voltage; when the source impedance increases, the power factor improves whereas the distortion rate (see page 4) of the voltage in the input of user installation increases.

It is the value of the distortion rate which determines the choice of the source. A distortion rate of 5 % is often the limiting value admissible for receiver installations that can be either polluters or polluted.

Curves in figure 23 page 14 show the variation of the global distortion rate of voltage in the input of the rectifier in function of two parameters:

- when the short-circuit voltage of the source varies from 0 to 8 %,
- for 3 values of resistive short-circuit voltage ( $U_{CCR} = 0$ ,  $U_{CCR} = 2\%$  and  $U_{CCR} = 4\%$ ).

They also show that, in practice, it is the inductive short-circuit voltage that determines the voltage distortion rate except when this short-circuit voltage is lower than 1 %.

### calculation of source power for supplying RCD type loads

Knowing the active power absorbed by the rectifier ( $P_r$ ), it is essential to choose correctly the power source ( $P_s$ ) that must supply it.

Uccx %	crest factor $\frac{I_{crest}}{I_{rms}}$	power factor $\lambda = \frac{P}{S}$	current spectrum $H_n \% = 100 \frac{I_n}{I_1}$						global distortion rate of voltage
			H3	H5	H7	H9	H11	H13	
0.25	2.7	0.64	87	64	38	15	1	7	2.8
0.5	2.63	0.65	85	60	33	11	4	7	3.5
1	2.51	0.68	81	52	24	6	7	6	5.4
2	2.35	0.72	76	42	14	7	6	3	7.5
4	2.19	0.75	69	29	8	8	4	4	11.2
6	2.1	0.77	63	21	8	6	3	3	14.2
8	2	0.78	59	17	8	5	3	2	16.8

fig. 22: variation of principle characteristic parameters of current and voltage for a computer type load supplied from a source of impedance  $U_{ccx}$  constant and equal to 2 % for values of  $U_{ccx}$  varying from 0.25 % to 8 %.

In our development hereafter, the impedance of the supply line is neglected (or integrated into  $U_{cc}$  of source).

A first indication is provided by the power factor:

$$\lambda = \frac{P}{S}$$

This power factor is dependent on the total short-circuit voltage upstream of rectifier but can be given a mean value of the order of 0.7.

Having established this first criterion, the power of the source must therefore be at least equal to the active power absorbed by the rectifier multiplied by

$$\frac{1}{0.7} \text{ or } 1.43.$$

The second criterion is related to a distortion rate that would be acceptable:

■ if a distortion rate of 5 % is envisaged, it is possible to retain an inductive short-circuit voltage of the

order of 1 % (in accordance with figure 23),

■ for a distortion rate of 10 %, a short-circuit voltage of the order of 3 % must be retained.

**For a transformer**

■ if  $U_{ccx} = 4 \%$

□ for  $D = 5 \%$  a power ratio of:

$$\frac{P_s}{P_r} = \frac{4\%}{1\%} = 4 \text{ is sufficient,}$$

□ for  $D = 10 \%$  the power ratio would be:

$$\frac{P_s}{P_r} = \frac{4\%}{3\%} = 1.33$$

but in this case, a value at least equal to 1.43 would be required by the power factor.

■ if  $U_{ccx} = 6 \%$

□ for  $D = 5 \%$  a power ratio of:

$$\frac{P_s}{P_r} = \frac{6\%}{1\%} = 6 \text{ is necessary,}$$

□ for  $D = 10 \%$ , a power ratio of 2 is required.

**Note:** for a transformer, it is often necessary to take a much higher power ratio considering that distortions can already be present in the network.

A distortion rate of 3 % due solely to the working of the rectifiers, leads one to retain an inductive short-circuit voltage of 0.45 % (in accordance with figure 23) which amounts to multiplying by 2.2 the power ratings of transformers to obtain a distortion rate of 5 %.

**For an alternator**

As distortion rates of 5 % and 10 % lead to inductive short-circuit voltages of 1 % and 3 % respectively, power ratios of alternator to rectifier are therefore equal to respectively:

$$\frac{U_{ccx}}{1\%} \text{ and } \frac{U_{ccx}}{3\%}$$

If  $U_{ccx} = 18 \%$ , it will be necessary:

■ for  $D = 5 \%$

to have a power ratio of:

$$\frac{P_s}{P_r} = 18$$

■ for  $D = 10 \%$

to have a power ratio of:

$$\frac{P_s}{P_r} = \frac{18\%}{3\%} = 6$$

**For an inverter**

■ classic inverter

As it was explained in our discussion on source impedances, this type of inverter of single phase mode exhibits an impedance comparable to that of an alternator of good design (with  $U_{ccx}$  of the order of 12 %).

As generally the output distortion of an inverter must be limited at 5 %, then it is desirable to retain a power ratio of the order of 12.

Inverters of the classic type are available today mostly in three phase version. In these, always assuming a distortion rate of 5 %, the power ratio is 7 when operated with a transformer whose secondary is connected in ZIGZAG.

■ PWM inverter with appropriate regulation

(reminder: its impedance is at least five times lower than that of a transformer for which the power rating must be multiplied by 4).

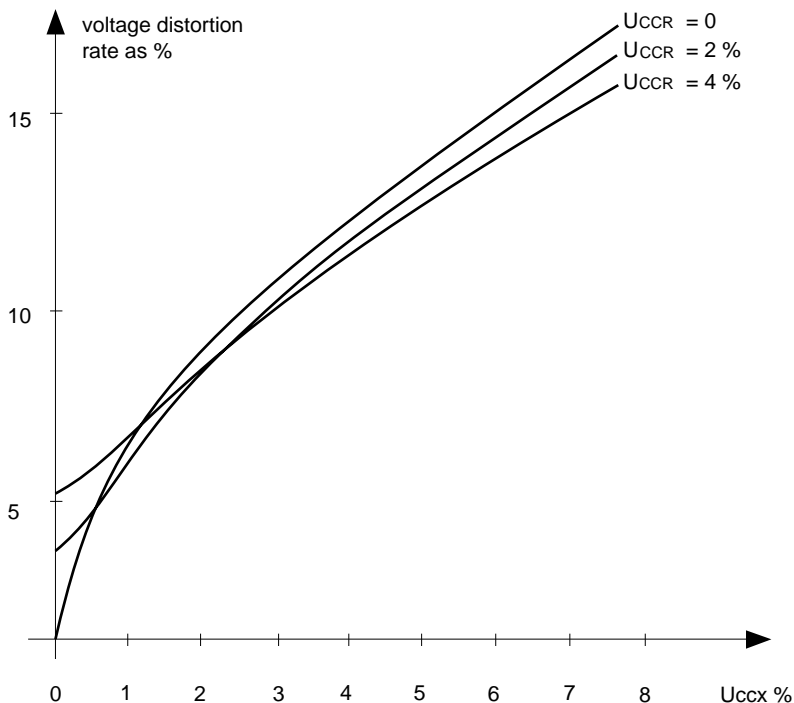

fig. 23: variation of voltage distortion rate at input of microprocessor type load with respect to  $U_{ccx}$  and several values  $U_{CCR}$  of the source.

As long as the current drawn by the load exhibits a crest value lower than the limiting threshold value for the equipment, the distortion rate remains very low and inferior to 5 %. As soon as the threshold limit is reached, the voltage supplied by the inverter becomes distorted (sine wave becomes affected by crest flattening) and the voltage distortion rate increases.

Experience shows that, in order to avoid a voltage distortion exceeding 5 %, it is necessary to set the threshold limit for current at 1.5 times the limit value of the nominal effective current of the inverter,

thus  $I_{\text{limit}} = 1.5 \sqrt{2} I_{\text{rms}}$ .

The corresponding crest factor of current is then equal to

$1.5 \sqrt{2}$  that is 2.12.

Figure 24 shows the variation (evolution) of voltage and current in a 5.2 kVA inverter with a threshold limit set at:

$$\frac{5,000}{220} \cdot 1.5 \cdot \sqrt{2} = 48 \text{ A}.$$

A voltage distortion rate of 5 % is reached here for an apparent power of 5.2 kVA, that is slightly greater than 5 kVA which is its design parameter for rating.

The power factor of the RCD load is, in this case very close to 0.8 (0.79) and consequently the inverter does not need to be over-dimensioned in order to supply this type of load (except when the distance between inverter and loads is relatively significant, this being however, true for all sources).

In the example shown in figure 24, a 5 kVA inverter is capable of supplying a 4 kW rectifier with a distortion rate inferior to 5 %.

$$\text{Thus } P_{\text{inverter}} = \frac{P_R}{0.8} = 1.25 P_R$$

It is worth noting that the fact of limiting the current improves the power factor.

In the preceding paragraph dealing with transformer, it was noticed that, with a power factor of rectifier amounting to 0.7, it was necessary, even in the absence of constraints on the distortion rate, to choose a transformer whose power rating was at least equal to  $1.43 P_R$ .

The PWM inverter appears therefore to be the ideal source of voltage for supplying not only loads of RCD type but also all receiver equipment which are generators of harmonic currents (non-linear loads).

In the preceding section, we have discussed the case of inverters and

single phase loads; the same reasoning can indeed be applied to three phase equipment providing the equipment is fitted with independent regulation in each phase (this is generally the case with this type of equipment).

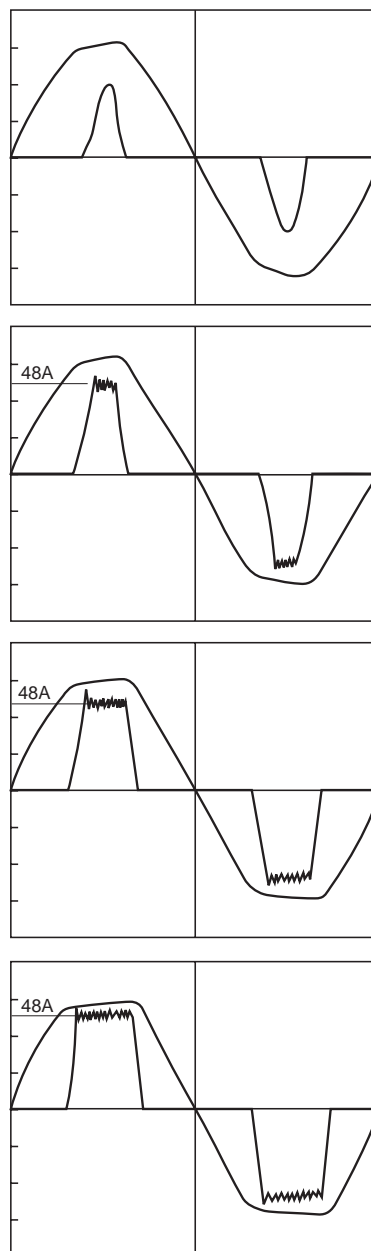

Urms	: 220 V
Irms	: 11 A
power factor	: 0.61
crest factor	: 3.6
distortion rate	: 2.7 %
apparent power	: 2.4 kVA
active power	: 1.5 kW

Urms	: 220 V
Irms	: 20 A
power factor	: 0.69
crest factor	: 2.4
distortion rate	: 3 %
apparent power	: 4.4 kVA
active power	: 3 kW

Urms	: 220 V
Irms	: 24 A
power factor	: 0.79
crest factor	: 2
distortion rate	: 5 %
apparent power	: 5.2 kVA
active power	: 4.17 kW

Urms	: 220 V
Irms	: 29 A
power factor	: 0.82
crest factor	: 1.64
distortion rate	: 10 %
apparent power	: 6.3 kVA
active power	: 5.2 kW

fig. 24: variation of output voltage of 5 kVA inverter with threshold limit set at 48 A.

## 5. conclusion

Static inverters equipped with PWM are nearly perfect sources of voltage. Besides their qualities as regards voltage stability and frequency stability, they are the best generators on the

market for supplying electronic and micro-processor loads. The high speed response of their regulation systems endows them with a very low «harmonic impedance»; thus enables

them to supply a low distortion voltage to receivers that are generators of harmonic currents (non-linear loads).

## appendix 1: influence of line impedances on voltage distortions

The end of paragraph 3 stresses the fact that it is desirable to supply «receivers» that are generators of harmonic currents by means of special lines.

This is true for loads of RCD type, but also for all «receivers» utilising power electronics such as rectifiers, battery chargers, speed controllers etc.

The use of a special line provides isolation of harmonics through impedance (see fig. 25).

### For a «clean» receiver

The distortion rate  $D_1$  is practically identical to  $D$ , and this is all the more true as the impedance of line  $Z_1$  is small compared with that of receiver  $Z_p$ .

### For a non-linear receiver

$D_2$  will be all the more lower as the sum  $Z_2 + Z_s$  will remain low, in other words as the non-linear «receiver» will have a low power rating in relation to its supply.

The following example shows more clearly the influence of  $Z_2$  on  $D$  and  $D_2$ .

Let's consider a set of micro-computer absorbing 10 kW at 230 V that is being supplied by a cable conductor 100 m long connected to a transformer.

### ■ characteristics of cable:

- section: 10 mm<sup>2</sup>,
- $L\omega = 0.1 \Omega/\text{km}$  at 50 Hz,
- $r = 20 \Omega/\text{km}$  for a 1 mm<sup>2</sup> section.

■ characteristics of transformer: 50 kVA (with  $U_{ccx} = 4\%$  et  $U_{CCR} = 2\%$ ).

It is necessary to calculate the impedances of the inductive short-circuit and resistive short-circuit of the transformer but referred to the active power of micro-computers, thus:

$$U'1_{ccx} = U1_{ccx} \cdot \frac{P_R}{P_s}$$

$$U'1_{CCR} = U1_{CCR} \cdot \frac{P_R}{P_s}$$

thus

$$U'1_{ccx} = 4\% \cdot \frac{10}{50} = 0.8\%$$

$$U'1_{CCR} = 2\% \cdot \frac{10}{50} = 0.4\%$$

■ first assuming that  $Z_2 = 0$  (load very close to transformer).

Curves in figure 23 will give  $D = 4.6\% = D_2$ .

■ it is necessary now to calculate  $D$  et  $D_2$  with a line 100 m/10 mm<sup>2</sup> (i.e. 100 m long and a section 10 mm<sup>2</sup>):

□ thus short-circuit impedances of the line referred to  $P_R$ :

$$U'2_{ccx} = l\omega \cdot \frac{P_R}{Un^2} \cdot 100$$

$$U'2_{CCR} = R \cdot \frac{P_R}{Un^2} \cdot 10$$

thus with:

$$l\omega = 0.1 \cdot \frac{100}{1,000} = 10 \text{ m}\Omega$$

$$r = 20 \cdot \frac{100}{1,000} \cdot \frac{1}{10} = 0.2 \Omega$$

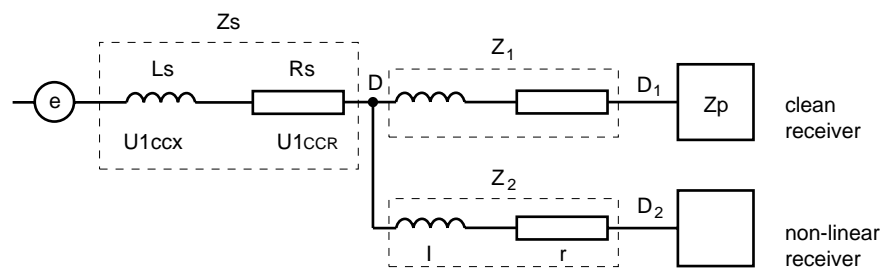

fig. 25: power supply through a specific line a receiver generator of harmonic currents.



$$U'_{2CCX} = 10 \cdot 10^{-3} \cdot \frac{10^4}{(230)^2} \cdot 100 = 0.19 \%$$

$$U'_{2CCR} = 0.2 \cdot \frac{10^4}{(230)^2} \cdot 100 = 3.8 \%$$

□ total short-circuit impedances:

$$U'_{CCX} = 0.8 \% + 0.19 \% = 0.99 \%$$

$$U'_{CCR} = 0.4 \% + 3.8 \% = 4.2 \%$$

thus

$$U'_{CCX} = U'_{1CCX} + U'_{2CCX}$$

$$U'_{CCR} = U'_{1CCR} + U'_{2CCR}$$

□ the voltage distortion rates  $D'_L$  and  $D'_R$  related to «impedances» of inductive short-circuits and resistive short-circuits.

These values are obtained from curves in figure 26a and figure 26b and are respectively

$$D'_L = 3.9 \%,$$

$$D'_R = 3.9 \%$$

□ distortion rate at input of personal computers:

$$D_2 = \sqrt{(3.9\%)^2 + (3.9\%)^2} = 5.52 \%$$

□ voltage distortion rates  $D_L$  and  $D_R$  at the source:

$$D_L = D'_L \cdot \frac{U'_{1CCX}}{U'_{CCX}}$$

$$D_R = D'_R \cdot \frac{U'_{1CCR}}{U'_{CCR}}$$

thus:

$$D_L = 3.9 \% \cdot \frac{0.8}{0.99} = 3.15 \%$$

$$D_R = 3.9 \% \cdot \frac{0.4}{4.2} = 0.37 \%$$

□ voltage distortion rate  $D$  at the source

$$D = \sqrt{D_L^2 + D_R^2}$$

$$D = \sqrt{(3.15\%)^2 + (0.37\%)^2} = 3.17 \%$$

□ in this example, the supply line causes  $D$  and  $D_2$  to change as follows

$D$  from 4.6 % to 3.17 %,

and  $D_2$  from 4.6 % to 5.52 %.

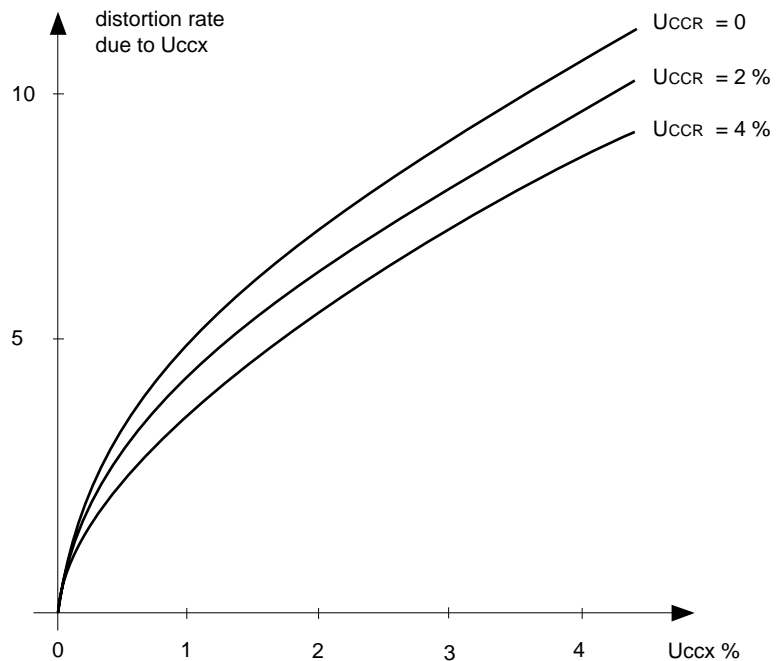

fig. 26a: voltage distortion rates due to  $U_{ccx}$  for various values of  $U_{CCR}$ .

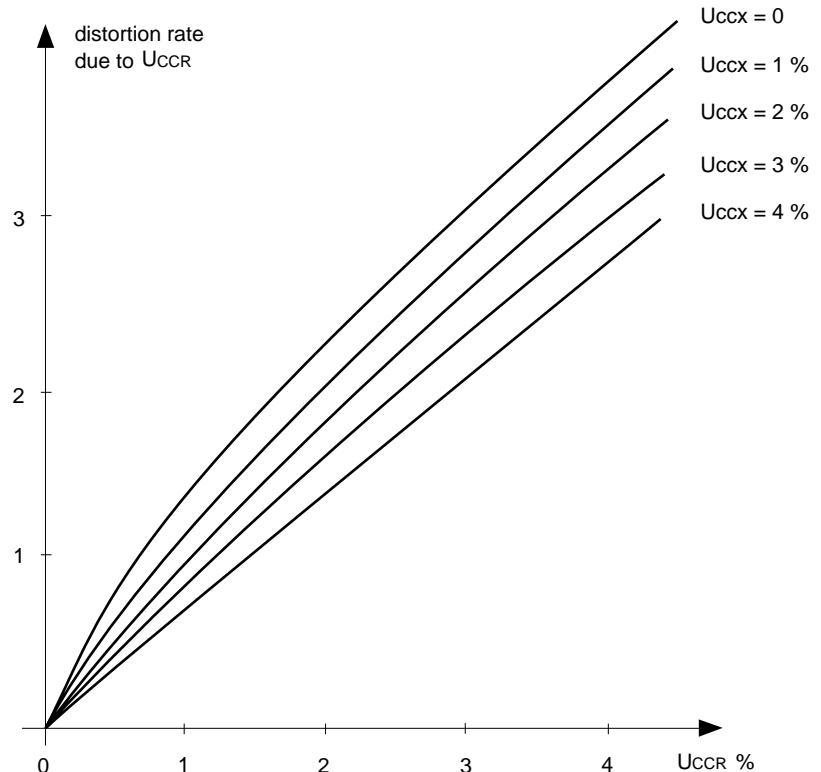

fig. 26b: distortion rates due to  $U_{CCR}$  for various values of  $U_{ccx}$ .

## appendix 2: input filters in computer/micro-processor equipment

Their purpose is to stop the propagation of disturbances caused by switched mode power supplies towards other equipment installations that could be adversely affected.

Conversely, they help attenuate some disturbances present in the network which are likely to alter the functioning of electronic and data information equipment.

The question is to know if these filters attenuate harmonic currents generated by RCD loads.

### Interference rejection in network

Switched mode power supplies operate at high frequencies in an effort to reduce the size and weight of transformers.

In figure 27, the load resistance  $R$  is the basic circuit shown in figure 19 is replaced by a transformer and its load. In this circuit, the line current remains identical because of the presence of capacitor  $C$ .

To achieve silent operation, the switching frequency is always high and in any case in excess of 20 kHz.

The commutation times of a transistor (change from non-conducting to conducting state and vice versa) are very brief and do not, in some cases, exceed a few tens of nano seconds.

These high frequency commutations (switching) do generate HF interference that is propagated by conduction and radiation. This gives rise to the presence of parasitic interference along the line upstream of the switching device, that is in the mains (on this subject, it is recommended to refer to «Cahier Technique» n° 149 «Electromagnetic Compatibility»).

In order to limit the circulation of these HF currents, constructors of data information processing equipment insert filters upstream of the switched mode power supply unit; a typical circuit of such filters is shown in figure 28.

These filters reduce disturbances:

- of common mode which affect in the same way both conductors with respect to earth,

- of differential mode which are present between the two conductors.

Inductance  $L$  offers a high impedance to currents of common mode but practically none to those of differential mode as its windings are wound in opposition.

Disturbances of common mode are conducted to earth by capacitors  $C_1$  and blocked by inductance  $L$ .

Disturbances of differential mode are attenuated by capacitors  $C_A$  and  $C_R$  which, at high frequency, offer a low impedance between the conductors.

### Protection of switched mode power supply

The filter inserted between the AC mains and the RCD supply ensures a second function: it protects the RCD supply from impulse type over-voltages and from HF interference of differential and common mode which are present in the mains.

### Leakages to earth

The presence of capacitors  $C_1$  causes a leakage current at 50 Hz to flow to earth.

Design standards generally specify values of leakage current not to be exceeded (a few milliamperes for equipment connected to a mains point). For example, standard specification IEC 950 relating to data processing equipment recommends that these leakage currents should be kept below 3.5 mA for equipment connected to a mains point.

In fact, currents of the order of 1 to 2 mA have been measured by UTE. If a line supplies several electronic and data processing equipment, the sum of the leakage currents can trip the highly sensitive differential residual current device (30 mA) inserted in the line.

### Filtering of harmonics

The filters inserted between the mains and the RCD supply operate efficiently in the frequency band-pass ranging from 10 kHz to 100 MHz.

Unfortunately, they are of no use against harmonic currents injected into the mains network.

This is due to the fact that harmonic currents produced by RCD supplies are of relatively low frequency: 1 kHz corresponds in fact to a harmonic of order 20 in relation to a fundamental at 50 Hz!

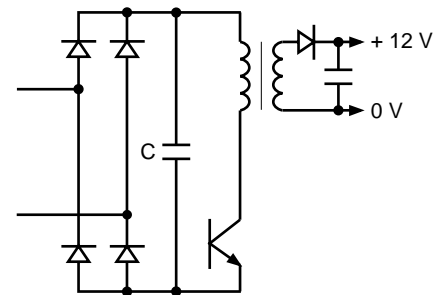

fig. 27: basic circuit diagram switched mode power supply to RCD load.

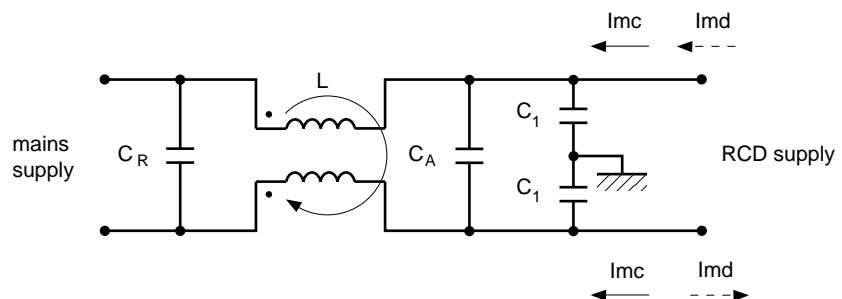

fig. 28: basic circuit diagram of an antiparasitic interference filter.

## appendix 3: bibliography

### Normes

■ IEC 146-1-1

Semi-conductor converters. General requirements and line commutated convertors - part 1-1: specifications basic requirements.

■ IEC 950

Safety of information technology equipment including electrical business equipment.  
(NF C 77-210, modification 1 incorporated).

■ NF C 42-810

Alimentations sans interruption, de puissance nominale inférieure à 3 kVA.

### Cahiers Techniques Merlin Gerin

■ «Analyse des réseaux triphasés en régime perturbé à l'aide des composantes symétriques»  
Cahier Technique n° 18  
- by B. De METZ-NOBLAT.

■ «EMC: electromagnetic compatibility»  
Cahier Technique n° 149  
- by F. VAILLANT.

