

# Offshore oil platform power and control system

# Summary

- I. Background
- II. Customer challenges
- III. Proposed solution
- IV. Customer benefits
- V. Conclusion

## **I. Background**

II. Customer challenges

III. Proposed solution

IV. Customer benefits

V. Conclusion

# I. Background

- Project scope

- Extract 230,000 bpd of crude oil
- Operate 300 miles off the Newfoundland Coast
- Harsh and dangerous operating conditions
  - Personnel subject to hypothermia / drowning
  - Equipment subject to corrosion by salt spray
  - Explosive environment
- 24/7 reliability, safety and scalability

- Project specifics

- A 160 feet high floating structure
  - Feed: 18 months
  - Building the platform: 2 years
  - Commissioning the platform: 2 years
- Gravity Base Structure (GBS): sitting on ocean floor and containing production storage tanks and ballast.
- Iceberg-resistant wall



I. Background



**II. Customer challenges**

III. Proposed solution

IV. Customer benefits

V. Conclusion

## II. Customer challenges

- Environmental conditions
  - North Atlantic, close to where Titanic sank...
  - Deep sea environment
  - Cold water (average temperature: 4°C)
  - Rough seas
  - Icebergs: 1.4 meter thick ice wall with 16 concrete teeth
- Operational constraints
  - 24/7 operations: no time for breakdown!
  - Remote location: reliability and scalability a must!
  - Must maximize production and safety
  - Sophisticated ballast control systems to ensure structure stability



# II. Customer challenges

- Vendor selection criteria

- PLC system must provide:
  - maximum MTBF,
  - robust immunity to radio transmission signals,
  - effective DCS communications
- Electrical distribution system must have:
  - high reliability,
  - proven track record, including arc-resistant capabilities.
- Equipment manufacturer must provide:
  - factory-trained and offshore-certified service personnel.

I. Background

II. Customer challenges



**III. Proposed solution**

IV. Customer benefits

V. Conclusion

# III. Proposed solution

- Power distribution System

- Complete Power distribution system, with ANSI rated switchgear

- Automation and control

- Modicon PLC controllers:
  - robust design & proven MTBFs,
  - tested radio interference operation
  - industry standard Modbus communications protocols.
- Modicon Hot Stand-By solution
  - proven redundant / back up Hot Stand-By solution
- MonitorPro software to control essential facilities:
  - helicopter fuelling systems, ballast, gas compressor, drilling, power generation, water treatment, concrete batch systems...

- Servicing

- Field service technicians offshore-certified and located nearby, provide:
  - commissioning,
  - 24/7 availability for ongoing issues.



# III. Proposed solution



**MV switchgear**



**MG MV breaker**

- Power distribution: MV

- Federal Pioneer 5/15 kV arc-resistant Metalclad switchgear
- Compartmentalized structure with fully grounded barriers
- Insulated bus providing highest degree of insulation
- Drawout breaker providing complete isolation of the switching component

# III. Proposed solution



**LV switchgear**



**Masterpact breaker**

- **Power distribution: LV**
  - Federal Pioneer LV switchgear with MG ANSI-rated, drawout CBs (600v, 100kA)
  - Complete modular assembly for easy maintenance and maximized uptime
  - High breaking capacity for exceptional equipment protection (200 kA interrupting capacity without fuse requirement)
  - Best in Class Safety clearance through Masterpact breaker internal filter, avoiding expulsion of hot gases when fault occurs.

# III. Proposed solution

- Automation: Hibernia system architecture

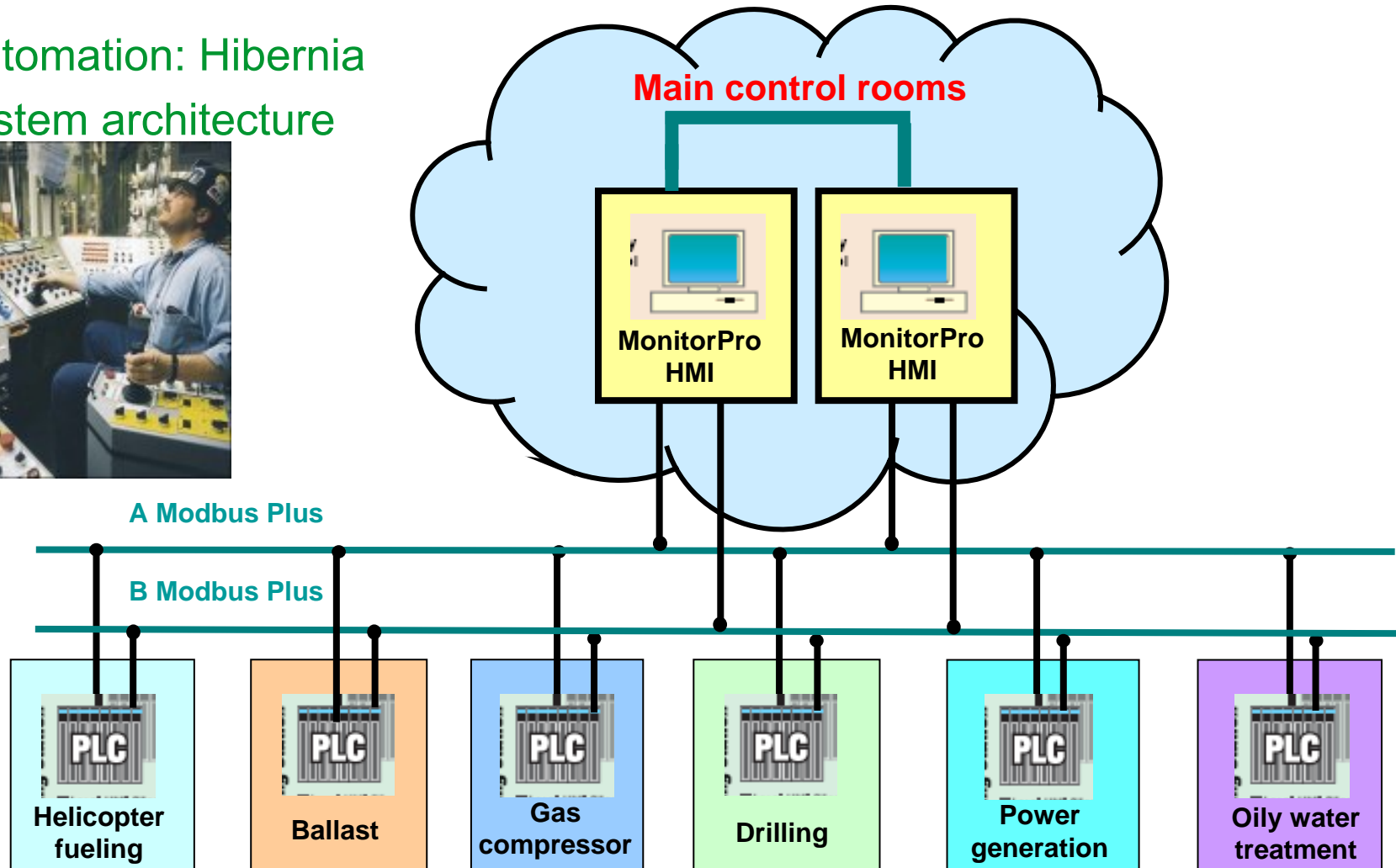

I. Background

II. Customer challenges

III. Proposed solution



**IV. Customer benefits**

V. Conclusion

# IV. Customer benefits

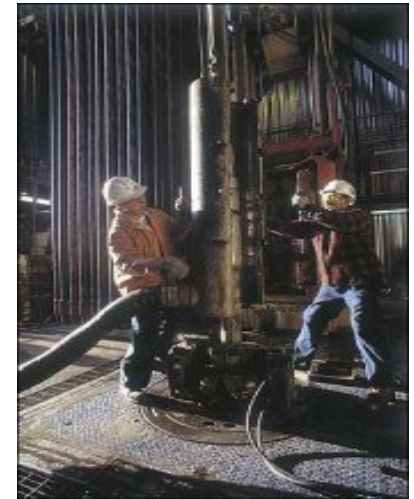

- Maximum uptime
  - Modicon PLCs are the most reliable piece of equipment on platform
    - No failures in 15 years of continuous operation (only one I/O card mechanically worn out over 10 years period)
    - Modicon PLC reported to have the highest MTBF on the platform
  - Opportunity to migrate via “Smooth Migration” program for Modicon Advanced Automation Systems
    - Currently under review by Hibernia Development
    - “Smooth Migration” will reduce downtime to a minimum:
      - All drawings, all wiring to or from modules to remain the same
      - Estimated time for changeover from OLD to NEW = 20 min. per drop
    - “Smooth Migration” brings flexibility to migrate either partially (hardware only) or fully (hardware and software), and in two folds:
      - A) Change PLC to new Quantum Series and Unity Software
      - B) Change the I/O in the field

## IV. Customer benefits

- **Improved personnel and equipment safety**
  - Employee safety maximized with MG breakers unique features
  - Reduced maintenance and improved service life with comprehensive and tested ranges of circuit-breakers
  - Scalability, reliability and redundancy of the Modicon PLC system recognized as the closest to a DCS system, while offering more flexibility.
  - Professional field services achieved through Offshore-certified technicians
- **Single source supplier and single source accountability**
  - Automation systems & control products
  - Power distribution equipments from main service entrance “downstream” to production
  - Project and supply chain management associated for Automation, Control and Power Distribution Equipment
  - Professional services from commissioning to upgrading

- I. Background
- II. Customer challenges
- III. Proposed solution
- IV. Customer benefits



## **V. Conclusion**

# V. Conclusion

- Background
  - 230,000 bpd of crude extracted in remote, harsh and dangerous environment
- Challenges
  - Maximize productivity and safety in a remote location
  - Maximize reliability of power distribution and automation equipment
  - Provide Offshore-certified field services technicians
- Solution
  - Arc-resistant switchgear & SF6 circuit breakers providing more than 35 years of proven experience
  - The most reliable PLCs
  - Professional services from commissioning to upgrading
- Customer benefits
  - Maximum uptime with highest MTBF recorded on Oil Platform
  - Maximum Personnel & Equipment safety
  - Single source supplier providing peace of mind



# The 3 main messages

- On this project, Schneider Electric exceeded the Customer's requirements by:
  - delivering maximum uptime
  - maximizing both Personnel & Equipment safety
  - being single source supplier and providing "peace of mind"

**Schneider Electric can provide a complete package to ensure smart, efficient and safe Power & Control**